

## Description:

- 18 gauge, 18-10 stainless steel, type 304
- **Two equal size bowls** - 17 x 14, 8" deep (43 x 35, 20 cm deep)
- **Overall size** - 19 x 31, 8" deep (48 x 79, 20 cm deep)
- 10 mm radius corners
- Centre rear drain location
- Flush divide centre separation
- Creased lines on bottom to improve drainage
- Satin bowls and ledge

## Recommended cabinet size:

- 33"

## Inclusions:

- Basket strainer: EA-114
- Undercoating and sound deadening pads
- Template
- Installation clips
- All sinks individually boxed

## Optional Accessories:

- Stainless steel bottom grid with rubber feet: **EBGF1714** fits either bowl
- Stainless steel roll mat with silicone wrapped bars: **ERM1914**
- Hardwood cutting board: **ECB1910**
- **Reference document available:**  
*Excalibur Sink Cross Reference to Accessories*

## Certifications:

- Sinks CUPC certified by IAPMO, strainers certified by CSA

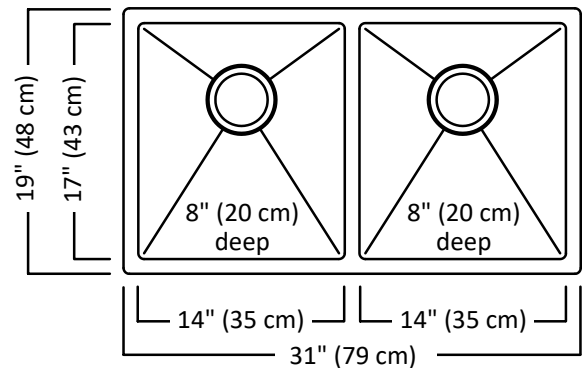

ECB1910  
Cutting Board



ERM1914  
Roll Mat

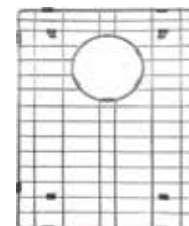

EBGF1714  
Bottom Grid

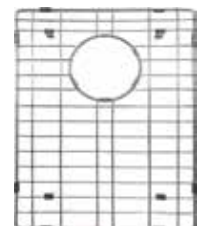

EBGF1714  
Bottom Grid

