

Description:

- 18 gauge, 18-10 stainless steel, type 304
- **Bowl size** - 16 x 27, 9" deep
(41 x 69, 23 cm deep)
- **Overall size** - 20 3/4 x 29 3/4, 9" deep
(53 x 76, 23 cm deep)
- 10 mm radius corners
- Flat front apron
- Rear drain waste hole location
- Creased bottom for improved drainage
- Undercoating and sound deadening pads
- Satin finished bowl, apron front and ledge

Recommended cabinet size:

- 33"

Inclusions:

- Basket strainer: EA-114
- Undercoating and sound deadening pads
- Template
- All sinks individually boxed

Optional Accessories:

- Stainless steel bottom grid with rubber feet: **EBGF1627**
- Stainless steel roll mat with silicone wrapped bars: **ERM1814**
- Hardwood cutting board: **ECB1810**
- **Reference document available:**
Excalibur Sink Cross Reference to Accessories

Certifications:

- Sinks CUPC certified by IAPMO, strainers certified by CSA

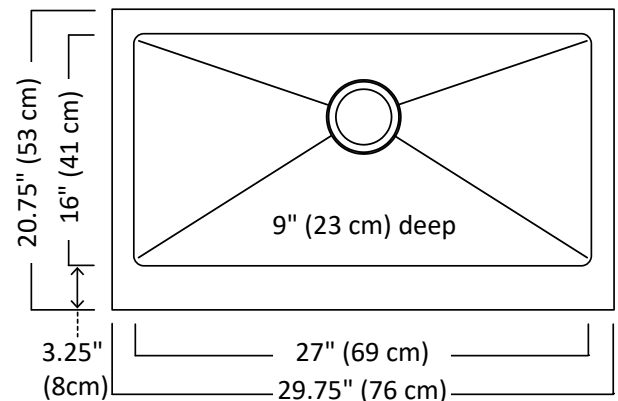

ECB1810
Cutting Board



ERM1814
Roll Mat

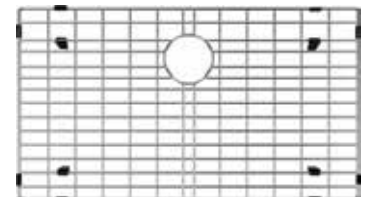

EBGF1627
Bottom Grid

